

Should I use preinsulated pipe?

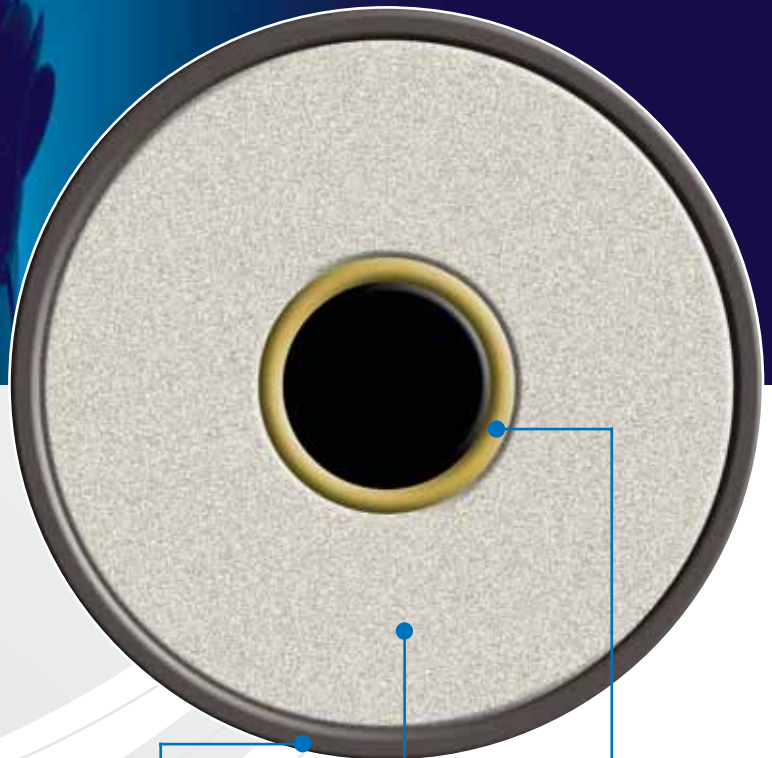

RIGID polyurethane pipe systems consist of a carrier pipe surrounded by a layer of polyurethane foam insulation and encased in a solid casing.

Used for conveyance of hot or cold media in aboveground or underground applications, **Rigitech®** Preinsulated pipe systems are excellent for any situation in which heat exchange with the environment needs to be minimized.



CARRIER PIPE

JACKET

INSULATION
(POLYURETHANE FOAM)

What kind of pipe can be preinsulated?

Virtually any type of rigid pipe system including copper, steel, stainless steel, PVC and HDPE can be preinsulated depending on the media to be carried. Standard 6m lengths can be manufactured with insulation thickness varying from 15mm to 150mm+.

Chilled water system with HDPE casing for underground application.



What are the benefits?

- Reduce on-site labour costs associated with insulation installation and supervision of staff and contractors,
- Accurately establish your installation costs in advance,
- Assurance of uniform product,
- High integrity vapour seals – the key to an effective insulation solution,
- No ongoing maintenance required when installed properly,
- Maximise insulation efficiency - Rigid polyurethane foam gives around one and a half to two times the insulation value of polystyrene or mineral wool fibre,
- CFC Free insulating materials,
- Negation of corrosion from environmental sources in underground systems.



Fire tested to AS1530 by the CSIRO - ZERO ON ALL INDICES

■ ABOVE GROUND APPLICATIONS

Spiral duct Casing – can be powdercoated
PVC Casing – less expensive option

■ UNDERGROUND APPLICATIONS/ BURIED SERVICE

High Density Polyethylene (HDPE) casing is used for its excellent mechanical and chemical properties – it is extremely strong, resists most chemicals (*no corrosion of carrier pipe*) and provides an excellent vapour barrier.

Comes with a range of preinsulated bend and tee kits for onsite installation. Used extensively in Chilled and Hot water reticulating systems.



USING RIGITECH® Preinsulated Pipes means you'll be dealing with a company proudly Quality Endorsed to ISO9001



LIC. NO. 22082

**rigi
tech**
Rigid Foam Products

45 Michael Street, Bulimba, Qld 4171
Telephone: +61 7 3395 7376 • Facsimile: +61 7 3395 7470
Website: www.rigitech.com.au • Email: sales@techpack.com.au